

HIGHLIGHTING

W-CDMA

Measurement of adjacent channel power on wideband CDMA signals

Use of FSE Spectrum Analyzer for adjacent channel power measurements with wideband CDMA signals is explained. Optimum operation is

shown by explanation the signal behavior and the internal structure of the FSE. The spectrum analyzer family FSE, featuring a very high dynamic

range is an outstanding equipment for this purpose. Up to 73 dB dynamic range are attained.



ROHDE & SCHWARZ

Considerations on dynamic range with W-CDMA signals

Measuring the spectral regrowth of wideband CDMA signals is one of most demanding measurements for a spectrum analyzer. The reasons are the signal behavior itself and the requirements needed for adjacent and alternate channel leakage needed for interference free communication.

At a first glance the signal within the transmit channels looks like white noise. But in terms of signal statistics it is different to white noise. The peak power of the signal depends on the number of coded channels transmitted. It can be, for example 13 dB, e.g. the peak power is 13 dB higher than the power measured using a power detector like a thermal power meter. In order not to distort the signal, and consequently generate spectral components in the adjacent channel, the spectrum analyzer must cope with these high peak amplitudes.

The requirements for wideband CDMA transmitters in terms of leakage in the neighbor channels are very high on the other hand. Requirements for

adjacent channel ratio measurement capability of 70 dB and more is a high demand for the measuring device.

Several parameters of the spectrum analyzer influence its inherent dynamic range:

- the load capability of the signal path without distorting the CDMA signal
- the thermal noise floor of the spectrum analyzer and
- the phase noise of the internal local oscillators.

As these requirements go to the limit of the dynamic capabilities of a spectrum analyzer, it has to be set up very carefully in order to attain optimum dynamic range. To do this, some understanding of the internal structure of a spectrum analyzer is necessary.

The following Fig. 1 shows a simplified block diagram of the FSEA Spectrum Analyzer:

The bandwidth and the 1-dB compression points correspond to the values of the FSEA 30. For the peak power levels of the W-CDMA signal a typical signal with a peak envelope power to

mean power ratio of 12 dB is assumed. Actual values depend on the type and number of code channels available within the CDMA signal.

Following conclusions can be made regarding the different bandwidths and power levels within the signal path of the FSE.

- The peak power of the signal is well above the measured channel power (12 dB in the example of Fig. 1). The peak power has to be within the linear region of the 1st mixer and the stages in front of the IF filter (RBW). This has to be considered when setting the input attenuation in order not to generate nonlinear distortion causing spectral regrowth. The peak envelope power should be about 10 dB below the 1-dB compression point of the signal path in front of the IF filter (RBW1, see Fig. 1).
- The trace shown on screen (level in front of the log amp) is 21.3 dB below the mean power level or 33.3 dB below the peak power level of the W-CDMA signal. This is due to the decrease of power proportional to the bandwidth reduction from 4.096 MHz to 30 kHz.

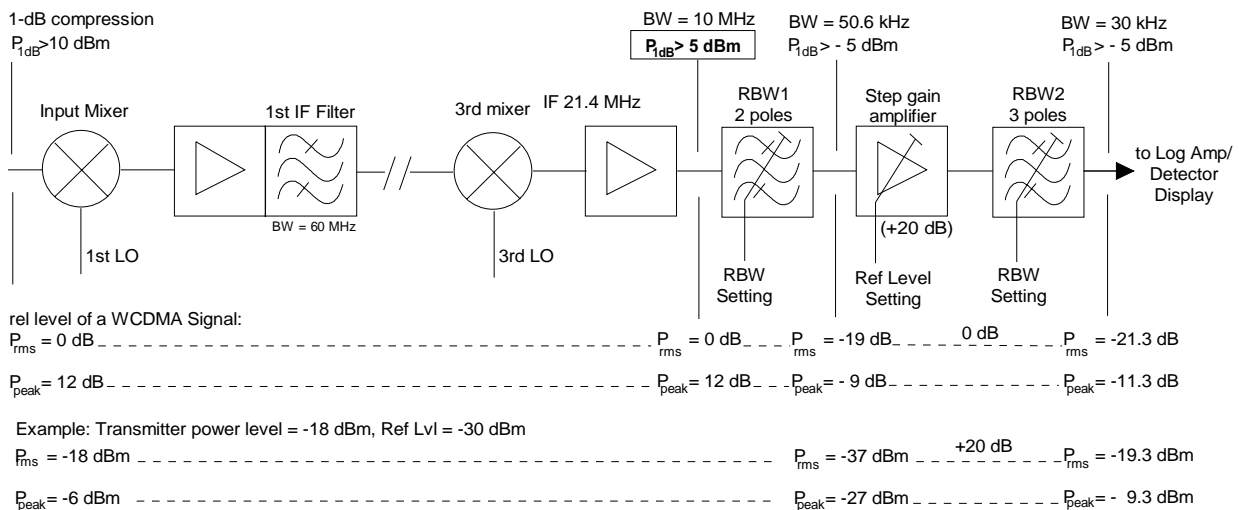

Fig. 1 Simplified block diagram of FSEA30 signal path (all levels are referred to RF input, resolution bandwidth is 30 kHz)

- The narrow resolution bandwidth compared to the signal bandwidth alters the amplitude probability distribution of the CDMA signal to a Gaussian distribution.
- The reference level setting should be decoupled from the input attenuator setting, because the step gain amplifier (see Fig. 1) which sets the reference level is loaded with a power 19 dB lower than the stages preceding the IF filter stage 1. The coupled settings for the input attenuator are optimized for CW signals with equal level independent of bandwidth. Decreasing the reference level with a fixed input attenuator setting (e.g. increasing the gain of the step gain amplifier) leads to a lower

noise floor of the FSE as the stages following the step gain amplifier do not contribute to the overall noise floor. The lowest noise floor is attained with a reference level setting 30 dB below the setting of the input attenuator, e.g. for 10 dB input attenuator setting reference level setting should be -20 dBm or less.

- When measuring in the adjacent channel the amplifier setting the reference level (step gain amplifier in Fig. 1) is not loaded by the transmit power. This allows a further decrease of the reference level resulting in a higher trace level in a more linear region of the display. The measurement uncertainty of the power measurement in the ad-

acent channels is improved due to the better linearity of the logarithmic amplifier and the detector. For minimal spectral regrowth due to the non-linearities of the internal signal path a low input mixer level is desirable. The lower limit is the internal noise floor of the FSE.

Low thermal noise floor is very important for high dynamic range with ACPR measurement as it determines the minimum power which can be measured. The noise figure of the FSEA is about 15 dB. This results in a noise power within 4.096 MHz channel bandwidth of -92.8 dBm according to the following formula:

$$\begin{aligned} \text{Noise Power Level} &= \\ -174 \text{ dBm} + 10 \cdot \lg\left(\frac{4.096 \times 10^6 \text{ Hz}}{1 \text{ Hz}}\right) \text{ dB} + 15 \text{ dB} \\ &= -92.8 \text{ dBm} \end{aligned}$$

where:

$$\begin{aligned} -174 \text{ dBm} &= \\ 4.096 \times 10^6 / \text{Hz} &= \\ 15 \text{ dB} &= \end{aligned}$$

the equivalent noise power of a 50-Ω resistor in 1 Hz bandwidth channel bandwidth of the W-CDMA transmit channel noise figure of the FSEA

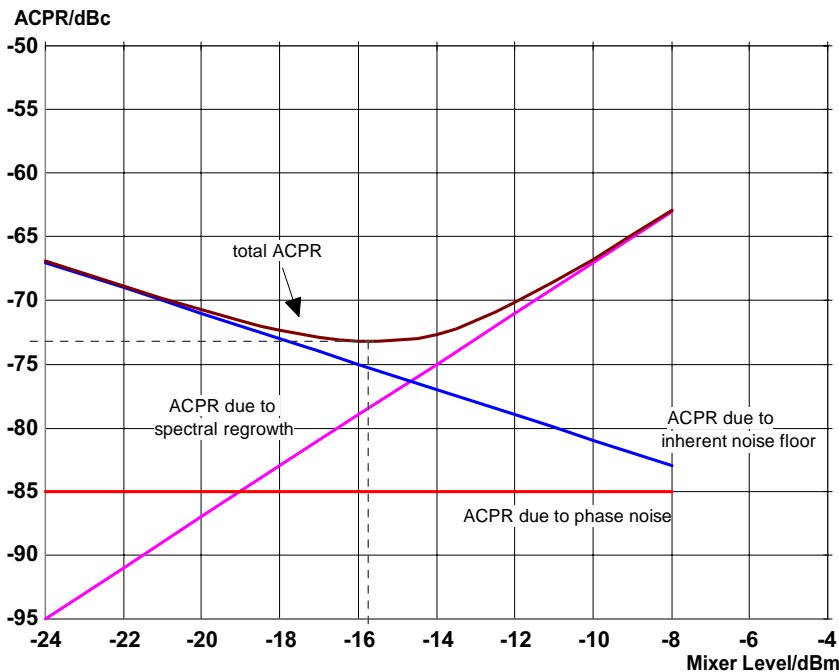

Fig. 2 Contributions for inherent ACPR of FSEA spectrum analyzer dependent on mixer level (= channel power at the input mixer)

The adjacent channel power ratio is the difference between the transmit channel power and the inherent noise power within the 4.096 MHz W-CDMA channel bandwidth. Therefore, it is desirable to have high power at the input mixer of the FSE to attain a high offset to the internal noise floor.

The third limiting factor for dynamic range is the phase noise of the internal local oscillators of the FSE. The high spectral purity of the FSE synthesizers leads to an inherent noise floor in the adjacent channel of about 80 dB below the transmit carrier power. Therefore it is not the limiting factor for dynamic range. The absolute level of phase noise decreases as the signal

power at the RF input is reduced. For this reason ACPR due to phase noise is independent of signal power at the RF input.

The following figure shows the contributions of the three limiting factors to the inherent maximum adjacent channel power ratio of the FSE (spectral regrowth, inherent noise floor and phase noise).

The horizontal axis of the diagram shows the channel power at the input mixer of the FSE. If RF attenuation is set to be >0 dB then it is the signal power minus the RF attenuation. The vertical axis shows the adjacent channel power ratio (ACPR) with 4.096 MHz bandwidth of the transmit and adjacent channel.

The phase noise of the internal local oscillators hardly contributes to the ACPR. The contribution of spectrum analyzer inherent noise floor to the ACPR result is reduced as the channel power of the signal is increased at the input mixer.

The ACPR due to spectral regrowth increases with a 2:1 slope by increasing the mixer level, e.g. by increasing the transmit power by 1 dB the relative power of the spectral regrowth increases by 2 dB. The behavior is like 3rd order intermodulation.

The power contribution of all three sources for adjacent channel power is summed up in the total ACPR curve. It shows an optimum mixer level range of -13 dBm to -19 dBm for maximum inherent ACPR ratio. The ACPR maximum achievable is about 73 dBc.

To set up the FSE for optimum dynamic range the following parameters have to be selected correctly.

Setup procedures and test results

Setting of input attenuator

The input attenuator has to be set so that the signal path prior to the IF filters is not overloaded. Optimum mixer level (e.g. level at RF input minus RF attenuation) is about -13 dBm to -19 dBm dependent on the crest factor of the W-CDMA signal. This may require an external attenuator, if the signal to be measured cannot be adjusted to the optimum mixer level range.

Example

Power level of transmitted signal = 19 dBm

Input attenuator setting = 30 dB

Mixer level = -11 dBm

Note: An additional 6-dB pad and an input attenuator setting of 30 dB result in nearly optimum mixer level.

Setting of reference level

Reference level setting results in a specific gain setting of the 21.4-MHz IF path. To minimize the influence of wideband noise after the IF filters and to maximize the overload capability for a wideband signal the gain is switched between the filter stages of the FSE. That way the reference level can be set in a wide range without causing intermodulation or overload. The RF attenuation has to be kept fixed, however. To be sure that the reference level is not exceeded trace 2 with detector Max Peak can be used in parallel to trace 1, to show the peaks of the filtered signal on screen. With peaks up to 3 dB above reference level the power is calculated correctly.

Resolution bandwidth setting

Resolution bandwidth has to be set narrow compared to the channel bandwidth in order not to widen the channel

bandwidth due to the high shape factor of spectrum analyzer filters. With resolution bandwidths between 0.5% to 5% of the channel bandwidth a good compromise can be attained between sweep time and bandwidth requirements of the transmit channel. With the 4 MHz channel bandwidth for wideband CDMA the recommended resolution bandwidth is between 20 kHz and 200 kHz. Lower bandwidths lead to long sweep times increasing the measurement speed unnecessarily. Wider bandwidths lead to overlapping of the channels due to the relatively poor selectivity of Gaussian type filters used in spectrum analyzer.

A further issue is the dependency on resolution bandwidth of the overall noise figure of the FSE. With 30 kHz resolution bandwidth lowest overall noise figure is attained. The reason is the implementation of the IF filters. With bandwidths between 1 kHz and 30 kHz the resolution filters are implemented using crystals operated in series resonance. For 50 kHz or wider resolution bandwidths lumped LC circuits are used operated in parallel resonance. In both cases the bandwidths of the resonators is set by variable resistors determining the Q factor of the resonators.

Due to the characteristics of the RBW filter implementation, lowest noise floor is achieved with a 30 kHz RBW setting. For 50 kHz bandwidth setting it is worst. With 50 kHz resolution bandwidth the noise is increased by about 6 dB compared to 30 kHz resolution bandwidth. With 100 kHz bandwidth the increase of noise figure is still about 2 dB.

Setting of the detector

For adjacent channel leakage the power in the different neighbor channels is specified, because the interfering power is the measure for degradation of transmission. To perform correct power measurements the rms

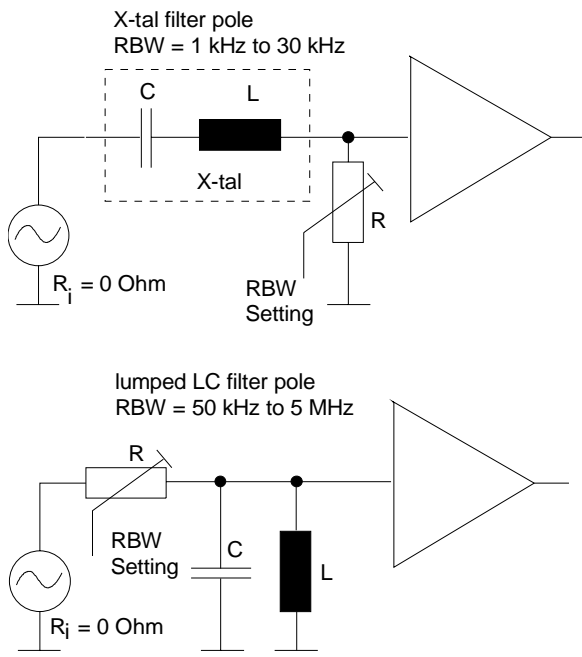

Fig. 3 Simplified schematic of an X-tal and an LC filter pole of the FSE

detector is recommended for signal detection as it measures power independent of signal shape and gives stable and repeatable results.

In the FSE, power calculation is performed on the linear video voltage using 16 bit word length for input and output of the power calculating ASIC. The 16-bit word length limits the dynamic range available on display to 96 dB. For accurate results the display range is limited to less than 80 dB due to the internal wordlength used. With lower levels relative to the reference level the resolution decreases up to 6 dB from -90 dB to -96 dB. The error due to the 16 bit resolution tends to be negative in any case because of the rounding algorithms used with the digital video filter and in the rms detector. It can be reduced partly by setting the video bandwidth to 10 MHz. In this case no video filtering occurs and therefore the rounding algorithm doesn't affect the test result.

With measurement of ACP ratios up to 65 dB this is not a problem (error

<0.5 dB). For higher ACP ratios this behavior can be overcome by measuring the power in the transmit channel and the adjacent channels separately. Due to the bandwidth reduction in front of the IF step amplifier used for setting the reference level, the reference level can be reduced by 20 dB

mit power measurement. This causes no overload in any stage of the signal path, if the RF attenuation is kept constant.

The following two examples show the setup procedure for ACPR measurement.

Example 1

FSE settings for ACP measurement up to 65 dB adjacent channel power ratio

- PRESET:
- CENTER: {input frequency of transmitter signal}
- SPAN: 15 MHz
- REF: -30 dBm; RF ATTEN MANUAL: 0 dB
- COUPLING:
- RES BW MANUAL: 30 kHz; SWEEP-TIME MANUAL: 2 s
- TRACE 1: DETECTOR: RMS
- MARKER NORMAL: (menu left):
- POWER MEAS SETTING:
- CHANNEL BANDWIDTH: 4.096 MHz
- CHANNEL SPACING: 5 MHz
- {menu up}
- ADJ CHAN POWER
- ACP/CP REL

Figure 4 shows the test results using the above settings:

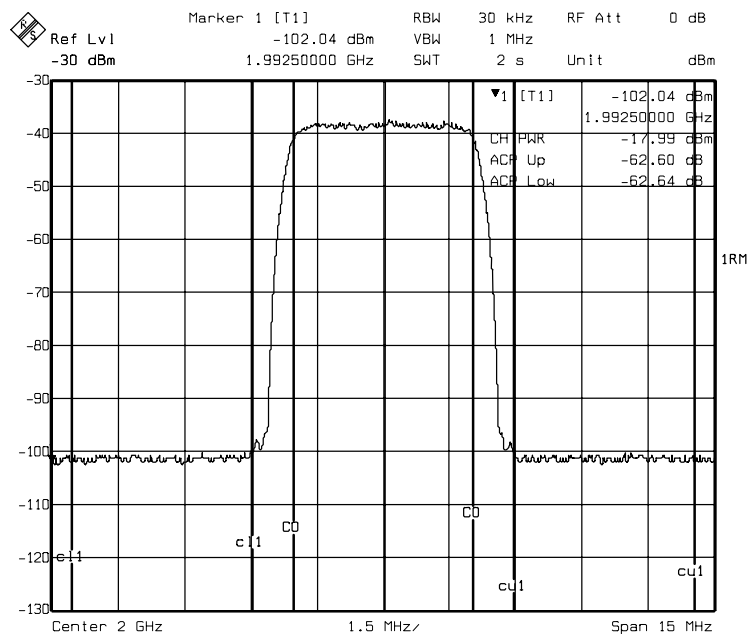

Fig. 4 Display of ACPR test result on FSE screen

Example 2

FSE settings for ACP measurement with adjacent channel power ratios of more than 65 dB

PRESET:

CENTER: {input frequency of transmitter signal}

SPAN: 4.5 MHz

REF: -30 dBm: RF ATTEN MANUAL: 0 dB

COUPLING:

RES BW MANUAL: 30 kHz: SWEEP-

TIME MANUAL: 500 ms

TRACE 1: DETECTOR: RMS

MARKER NORMAL: (menu left):

POWER MEAS SETTING:

CHANNEL BANDWIDTH: 4.096 MHz

CHANNEL SPACING: 5 MHz

(-> results in a 5-MHz step size of the up/down keys) {channel power of signal is measured, after one complete sweep press:} {press menu up key}

CHANNEL POWER:

ACP/CP REL: SET CP REFERENCE

Decrease reference level by 20 dB:

REF: -50 dBm

CENTER: {use up and down keys for switching to the adjacent channels}

Using the up key the FSE center frequency is stepped to the upper adjacent channels in 5-MHz steps, with the down key FSE center frequency is stepped to the lower adjacent channels.

The following figures show the channel power in the transmit channel and in the upper adjacent channels.

Measurement is performed at a transmit channel center frequency of 44.1 MHz because of the availability of low ACP signal. Adjacent channel power can be read out in Fig. 6 to be

-71.69 dBc. This value matches the ACPR predicted in Fig. 2 for a mixer level of -19.1 dBm very well.

Josef Wolf

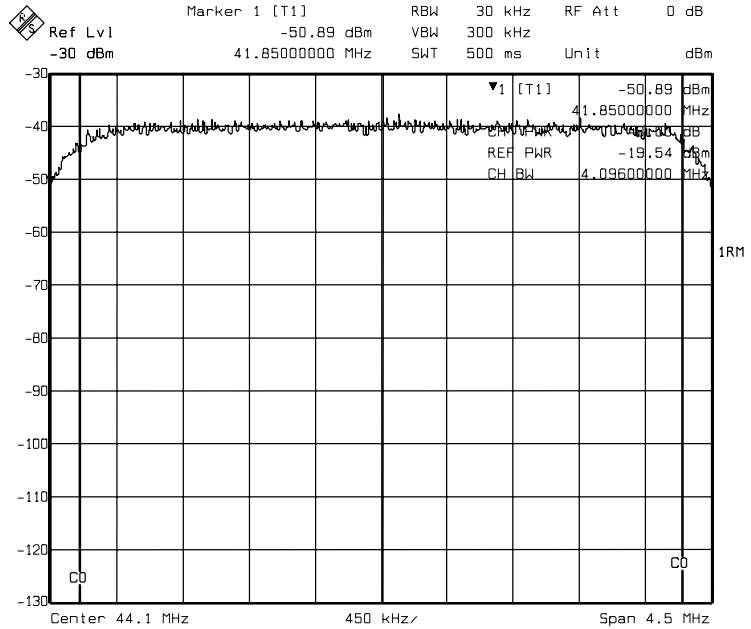

Fig. 5 Measurement of channel power in the transmit channel

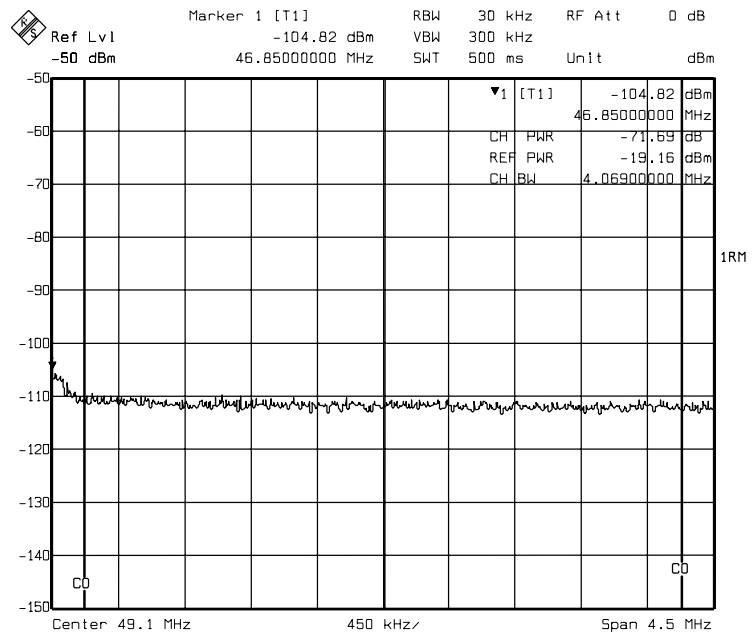

Fig. 6 Measurement of channel power in the upper adjacent channel



ROHDE & SCHWARZ